

## ASSEMBLING INSTRUCTIONS FOR LOADING RAMP

Before installing the ramp try to put it into your van, verify dimensions checking that the back door closing correctly. If the upper part of the door goes back toward the inner side, you can modify the inclination of the ramp through the regulating screws.

### ***FIRST USE***

- Make sure that there are no damages due to the transport. The ramp should be easy to fold in and out.
- Before installing and using the ramp, read carefully the instructions and save them for future reference.
- On each ramp you will find a sticker that shows the maximum load that the ramp can tolerate; the sticker also shows the maximum height that the ramp is suitable for.

1)

Once verified the dimensions, mark the holes of the fixing plates on the vehicle's frame plane. Before making the holes make sure that there are not cables, pipe, or something else.

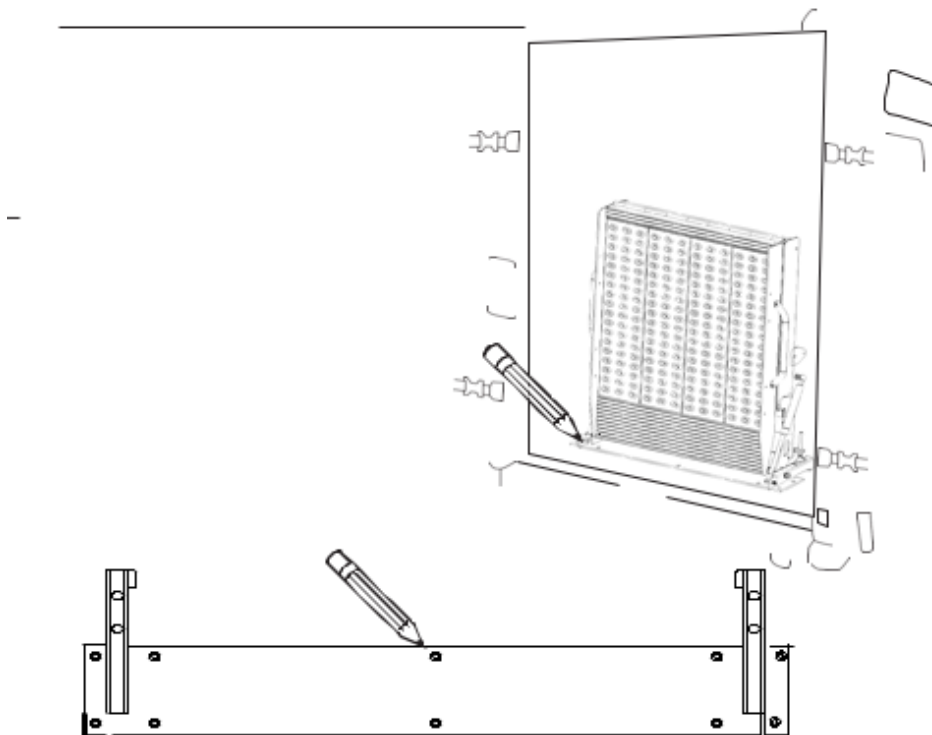

2)

Remove the ramp from the van and make holes 10.5 mm in diameter.

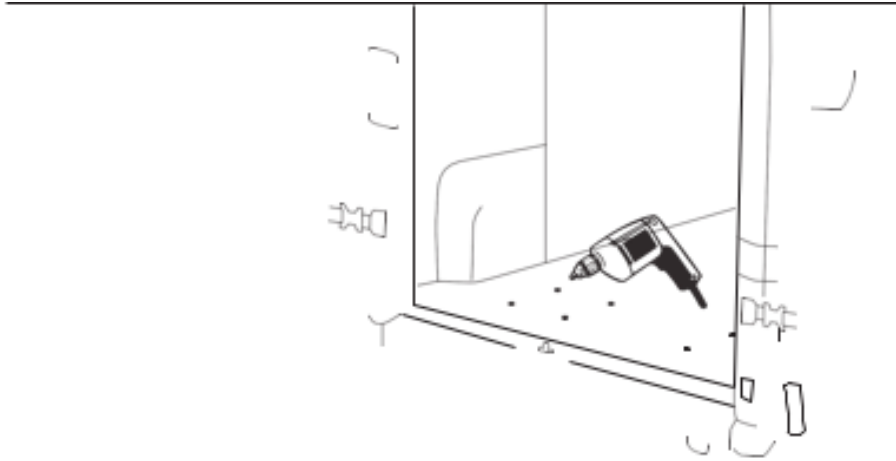

3)

Once made holes, install the ramp with screws, washers and galvanised, or stainless steel nuts.

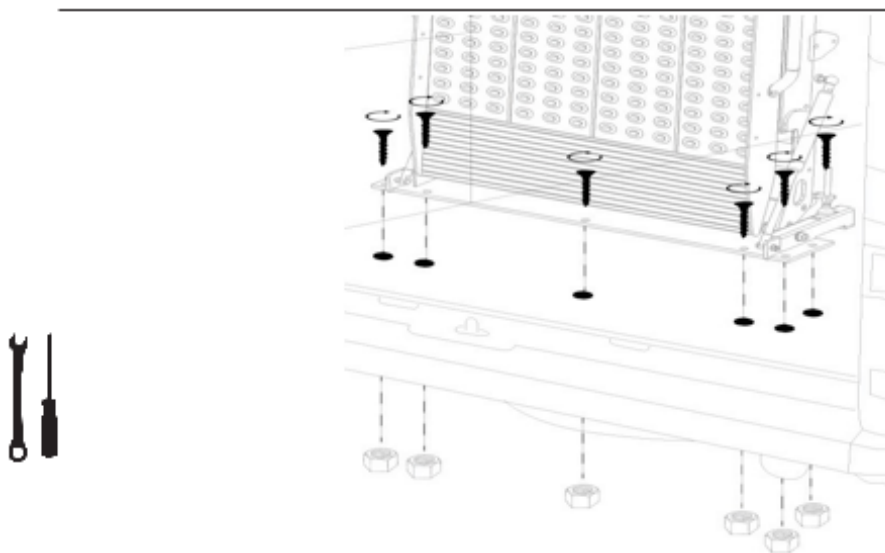

4)

a)

Proceed as though in the point number 1; mark the holes of the L shaped plates on the vehicle's frame plane.

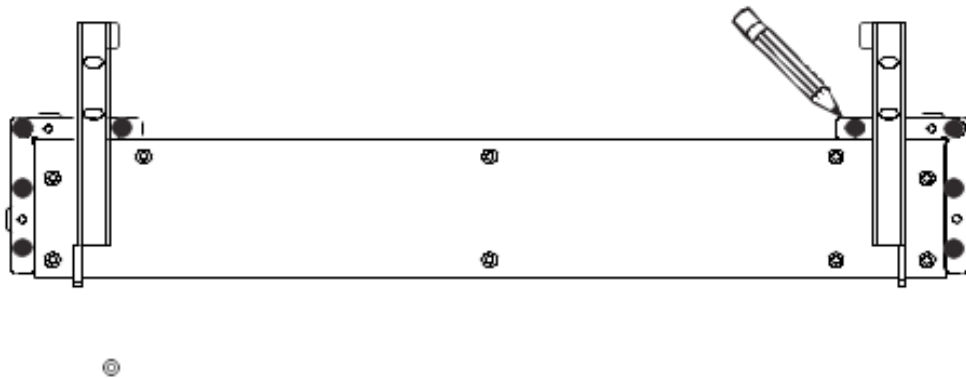

b)

Proceed as though the point number 2 and 3, but consider the L shaped plates.



5)

The Ramp is now ready to use.

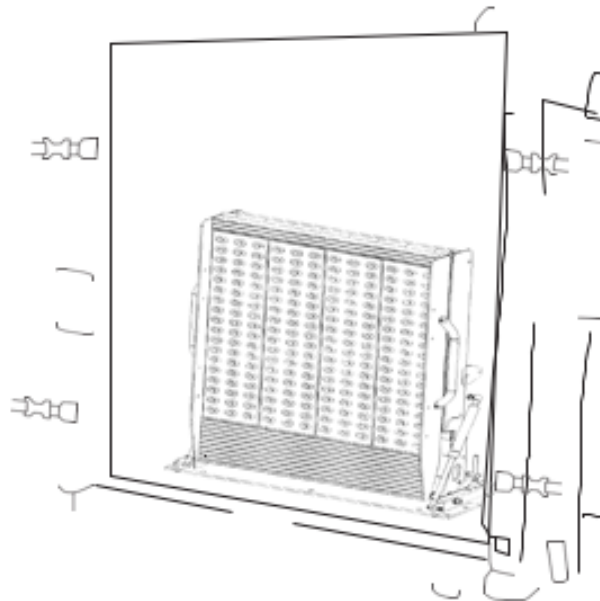

## REGULAR USE

- Make sure that the vehicle is on a flat surface with the handbrake applied.
- Catch the handle with both hands and open the ramp.
- Pay attention while handling the ramp.
- After using it, refold the ramp and close the safety hook.
- It is suggested to assure the ramp at the vehicle with safety belts.
- The Ramp People declines every responsibility about fixing and safety devices if not correctly assembled.

